

CS 261

Fall 2016

Mike Lam, Professor

Memory

Topics

- Memory hierarchy overview
- Storage technologies
 - SRAM
 - DRAM
 - PROM / flash
 - Disk storage
 - Tape and network storage
- I/O architecture
- Storage trends
- Latency comparisons

Memory

- Until now, we've referred to “memory” as a black box
- Modern systems actually have a variety of memory types called a **memory hierarchy**
 - Frequently-accessed data in faster memory
 - Other data in slower memory
 - Each level **caches** data from the next lower level
- Goal: large general pool of memory that performs *almost* as well as if it was **all** made of the fastest memory
- Key concept: **locality** of time and space

Memory hierarchy

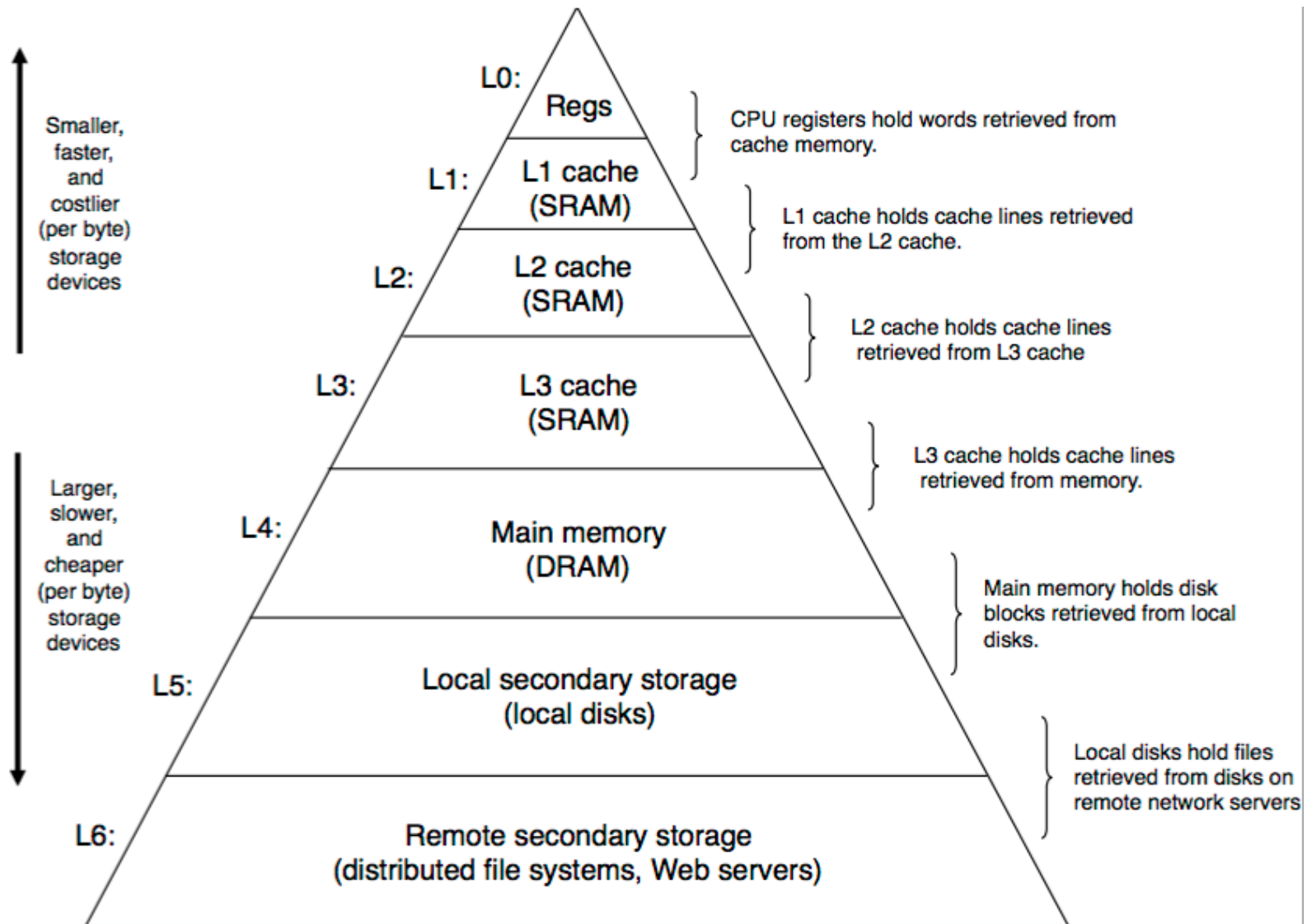

RAM

- **Random access memory**
 - Smaller pools of fast memory, closer to the CPU
 - Eventually lose data if the supply voltage is turned off
 - **Static RAM (SRAM)**
 - Six transistors per bit in a circuit w/ feedback loops
 - Essentially the same as discussed in Ch. 4
 - Used for CPU caches; usually <1GB
 - **Dynamic RAM (DRAM)**
 - One capacitor per bit with a single access transistor
 - Must be refreshed periodically
 - Used for main memory and graphics memory
 - Usually <64 GB

DRAM

- DRAM chips store data in a grid of **supercells**
- **Memory controller** used to access data
 - Connected to CPU via memory bus
 - Row access strobe (RAS) request
 - Column access strobe (CAS) request

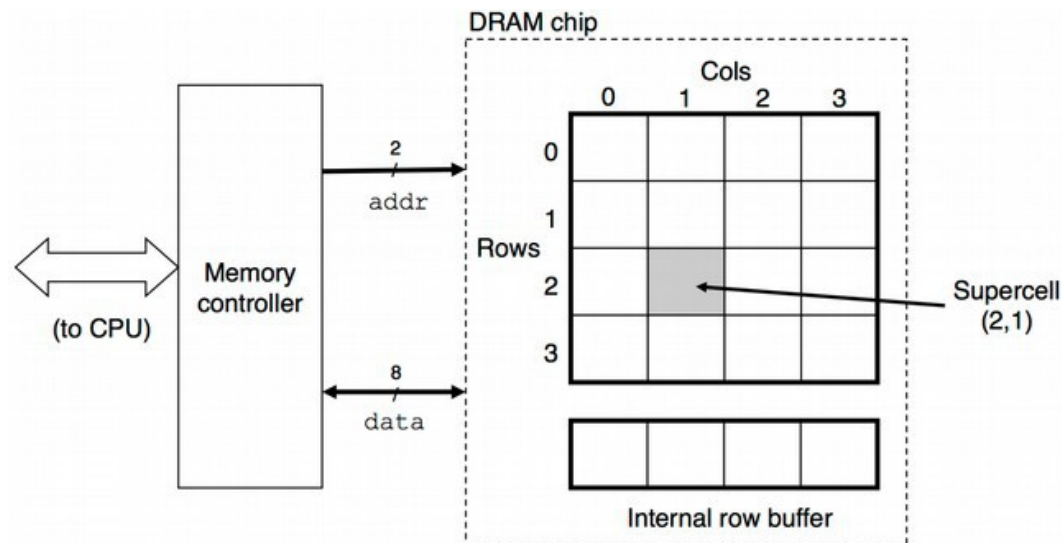

Enhanced DRAM

- **Fast page mode DRAM** (FPM DRAM)
 - Serve same-row accesses from a row buffer
- **Extended data out DRAM** (EDO DRAM)
 - Allow CAS signals to be more closely spaced
- **Synchronous DRAM** (SDRAM)
 - Use a clock to synchronize and speed accesses
- **Double data-rate SDRAM** (DDR SDRAM)
 - Use both rising and falling edges of clock signal
- **Video RAM** (VRAM)
 - Shift an entire buffer's contents in a single operation
 - Allow simultaneous reads and writes

Nonvolatile memory

- **Nonvolatile memory** retains data if the voltage is turned off
 - Historically referred to as **read-only memory** (ROM)
 - Newer forms of nonvolatile memory can be written
- **Programmable ROM** (PROM)
 - Programmed only once by blowing fuses
- **Erasable PROM** (EPROM)
 - Re-programmed using ultraviolet light
- **Electrically-erasable PROM** (EEPROM)
 - Re-programmed using electric signals
 - Basis for **flash memory** storage devices

Disk storage

- **Disk storage** systems hold large amounts of data
 - More cost effective than SRAM or DRAM
 - Usually order of magnitudes slower
- **Solid-state drives** (SSDs)
 - Flash memory organized into blocks
- Traditional **hard disk drives** (HDDs)
 - Multiple **platters** with **surfaces** coated with magnetic material
 - Accessed using a physical arm with a magnetic head
 - Data stored on surface in **tracks** partitioned into **sectors**

Hard disk drives

- Capacity is based on **areal density**
 - Product of **recording density** and **track density**
- Operation requires mechanical motion
 - Magnetic read/write head on an **actuator arm**
- Speed is based on average **access time**
 - Sum of **seek time**, **rotational latency**, and **transfer time**
 - Platters spin at standard rate
- **Disk controller** coordinates accesses
 - Maps **logical blocks** to (surface, track, sector) numbers



Tape and network storage

- **Archival** storage systems provide large-scale data storage
 - Lowest cost per byte, but slowest access
- **Tape drives** store data on magnetic tape
 - Often in an off-site location for added redundancy
- **Network-attached storage (NAS)** systems
 - Dedicated data storage server
 - Often uses redundant disks for reliability (RAID)
 - Communicate over a network via a file sharing protocol
 - Examples: NFS, Samba, AFS
 - *More about this in CS 361 and CS 470!*

I/O architecture

- **Cache memory** (SRAM)
 - Access via direct connection to CPU (or on-die)
- **Main memory** (DRAM)
 - **Bus transactions** via **I/O bridge** on motherboard
- **Disk drives** (spinning disk & SSD)
 - Connected to I/O bridge via **I/O bus**
 - Requires a **device controller** for communication
 - Memory transactions w/o CPU via **direct memory access** (DMA)
 - Technologies: **USB**, **SATA**, **SCSI**
- **Other memory** (graphics, network storage)
 - Connected to I/O bus using **expansion slots** on motherboard

I/O architecture

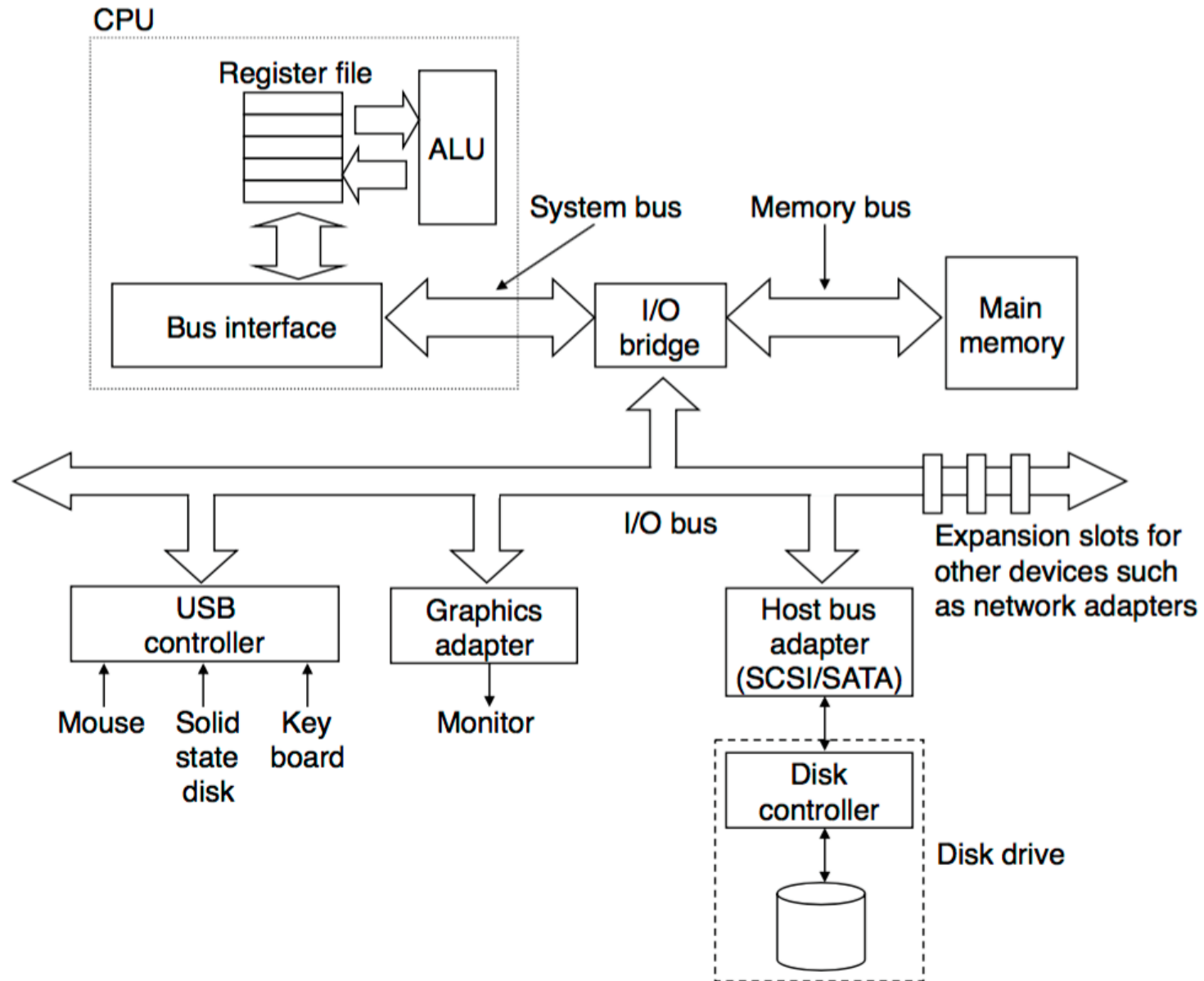

DMA

- 1) CPU initiates disk read
- 2) Disk reads data
- 3) Disk writes RAM via DMA
- 4) Disk notifies CPU

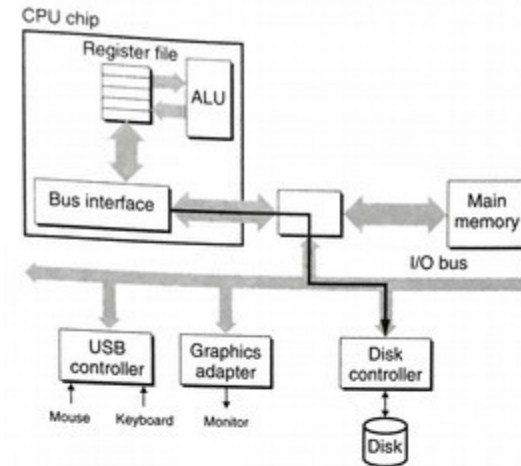

(a) The CPU initiates a disk read by writing a command, logical block number, and destination memory address to the memory-mapped address associated with the disk.

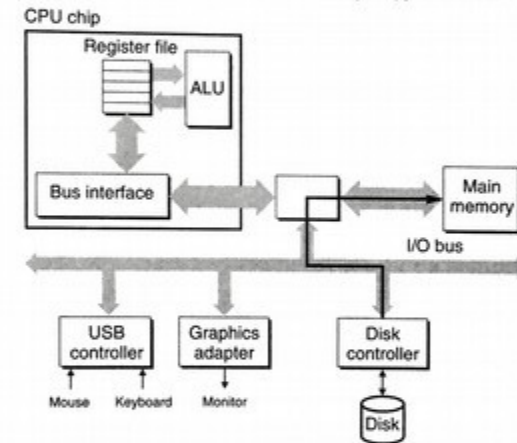

(b) The disk controller reads the sector and performs a DMA transfer into main memory.

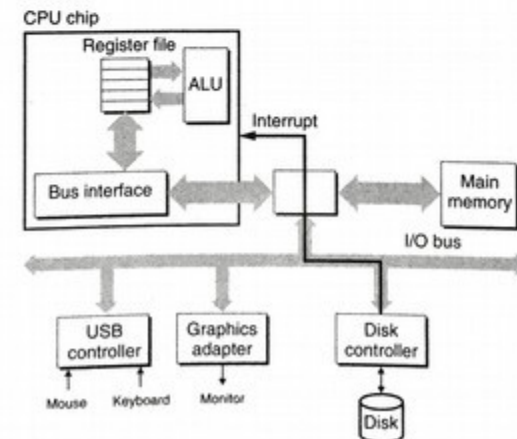

(c) When the DMA transfer is complete, the disk controller notifies the CPU with an interrupt.

Storage trends

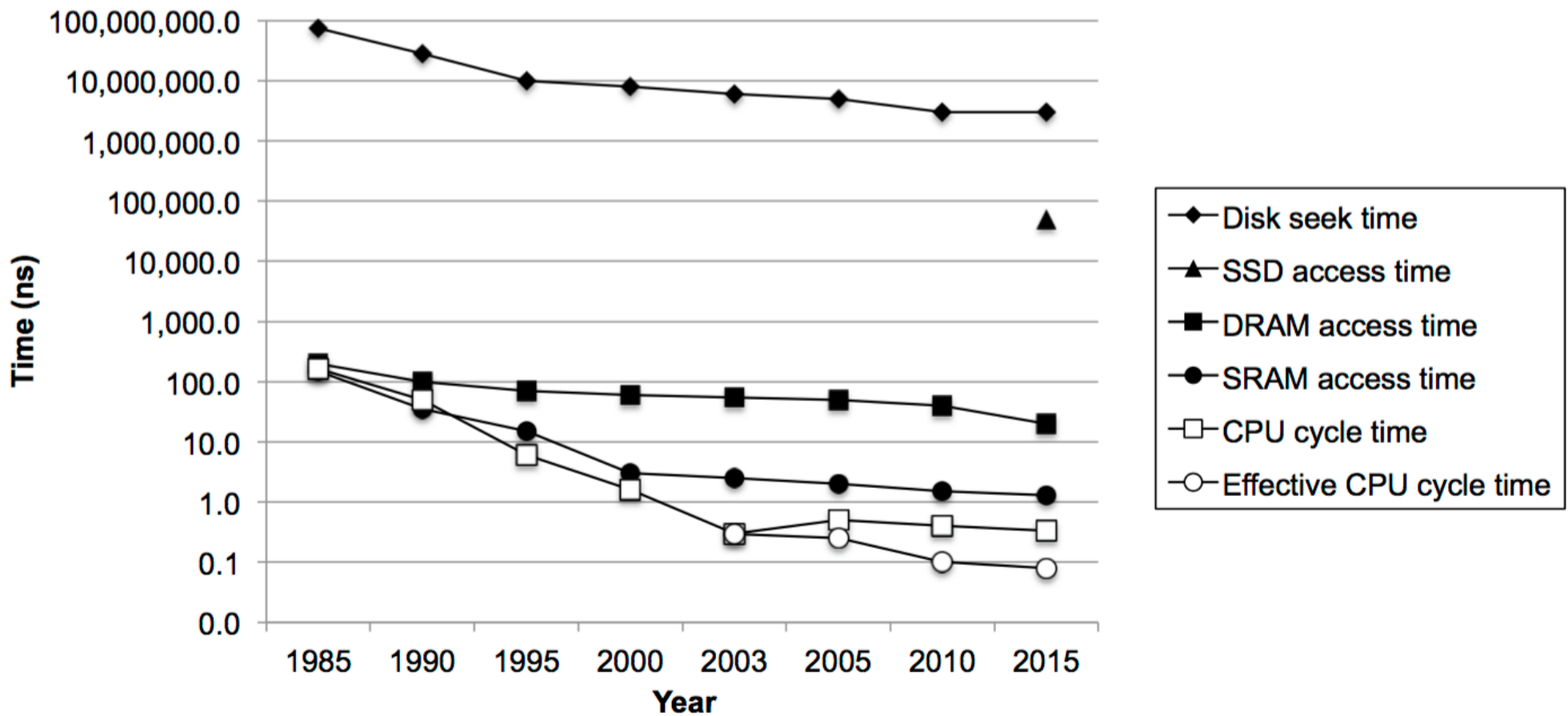

Storage trends

Metric	1985	1990	1995	2000	2005	2010	2015	2015:1985
\$/MB	2,900	320	256	100	75	60	25	116
Access (ns)	150	35	15	3	2	1.5	1.3	115

(a) SRAM trends

Metric	1985	1990	1995	2000	2005	2010	2015	2015:1985
\$/MB	880	100	30	1	0.1	0.06	0.02	44,000
Access (ns)	200	100	70	60	50	40	20	10
Typical size (MB)	0.256	4	16	64	2,000	8,000	16,000	62,500

(b) DRAM trends

Metric	1985	1990	1995	2000	2005	2010	2015	2015:1985
\$/GB	100,000	8,000	300	10	5	0.3	0.03	3,333,333
Min. seek time (ms)	75	28	10	8	5	3	3	25
Typical size (GB)	0.01	0.16	1	20	160	1,500	3,000	300,000

(c) Rotating disk trends

Metric	1985	1990	1995	2000	2003	2005	2010	2015	2015:1985
Intel CPU	80286	80386	Pent.	P-III	Pent. 4	Core 2	Core i7 (n)	Core i7 (h)	—
Clock rate (MHz)	6	20	150	600	3,300	2,000	2,500	3,000	500
Cycle time (ns)	166	50	6	1.6	0.3	0.5	0.4	0.33	500
Cores	1	1	1	1	1	2	4	4	4
Effective cycle time (ns)	166	50	6	1.6	0.30	0.25	0.10	0.08	2,075

(d) CPU trends

Storage trends

Metric	1985	1990	1995	2000	2005	2010	2015	2015:1985
\$/MB	2,900	320	256	100	75	60	25	116
Access (ns)	150	35	15	3	2	1.5	1.3	115

(a) SRAM trends

Metric	1985	1990	1995	2000	2005	2010	2015	2015:1985
\$/MB	880	100	30	1	0.1	0.06	0.02	44,000
Access (ns)	200	100	70	60	50	40	20	10
Typical size (MB)	0.256	4	16	64	2,000	8,000	16,000	62,500

(b) DRAM trends

Metric	1985	1990	1995	2000	2005	2010	2015	2015:1985
\$/GB	100,000	8,000	300	10	5	0.3	0.03	3,333,333
Min. seek time (ms)	75	28	10	8	5	3	3	25
Typical size (GB)	0.01	0.16	1	20	160	1,500	3,000	300,000

(c) Rotating disk trends

Metric	1985	1990	1995	2000	2003	2005	2010	2015	2015:1985
Intel CPU	80286	80386	Pent.	P-III	Pent. 4	Core 2	Core i7 (n)	Core i7 (h)	—
Clock rate (MHz)	6	20	150	600	3,300	2,000	2,500	3,000	500
Cycle time (ns)	166	50	6	1.6	0.3	0.5	0.4	0.33	500
Cores	1	1	1	1	1	2	4	4	4
Effective cycle time (ns)	166	50	6	1.6	0.30	0.25	0.10	0.08	2,075

(d) CPU trends

Faster

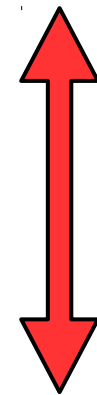

Cheaper

Effective cycle times continue to decrease

Latency comparison

Latency Numbers Every Programmer Should Know

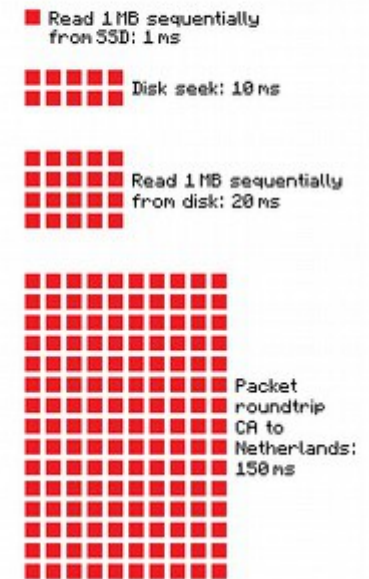
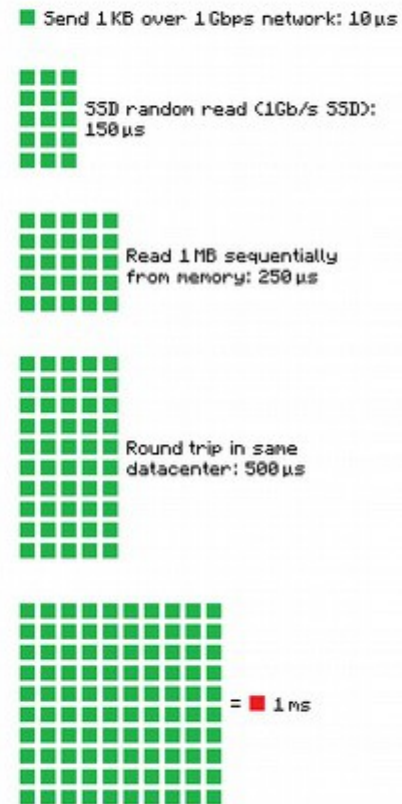
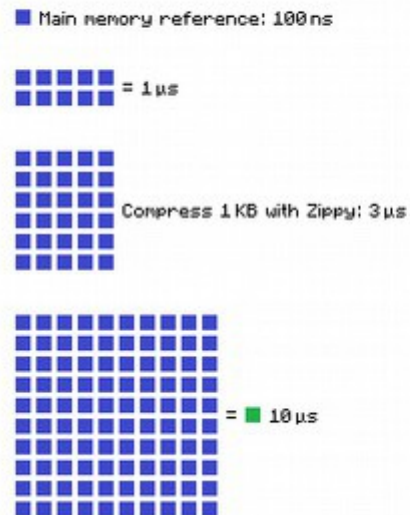
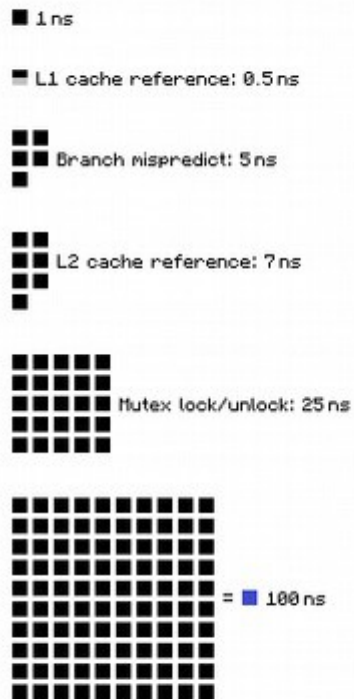

Source: <https://gist.github.com/2841832>

Latency comparison

Lets multiply all these durations by a billion: (originally from <https://dzone.com/articles/every-programmer-should-know>)

Minute:

L1 cache reference (0.5s) - *One heart beat*

L2 cache reference (7s) - *Long yawn*

Hour:

Main memory reference (100s) - *Brushing your teeth*

Day:

Send 2K bytes over 1 Gbps network (5.5 hr) - *From lunch to end of work day*

Week:

SSD random read (1.7 days) - *A normal weekend*

Read 1 MB sequentially from memory (2.9 days) - *A long weekend*

Read 1 MB sequentially from SSD (11.6 days) - *Waiting for almost 2 weeks for a delivery*

Year:

Disk seek (16.5 weeks) - *A semester in university*

Read 1 MB sequentially from disk (7.8 months) - *Almost producing a new human being*

The above 2 together (1 year)

Decade:

Send packet CA->Netherlands->CA (4.8 years) - *Average time to complete a bachelor's degree*

Core themes

- **Systems design involves tradeoffs**
 - Memory: price vs. performance
- **The details matter!**
 - Knowledge of the underlying system enables you to exploit latency inequalities
- Key concepts: **locality** and **caching**
 - Store and access related things together
 - Keep copies of things you'll need again soon
 - We'll look at these more next time