

Convolutional Neural Networks

Nathan Sprague

Human Visual System

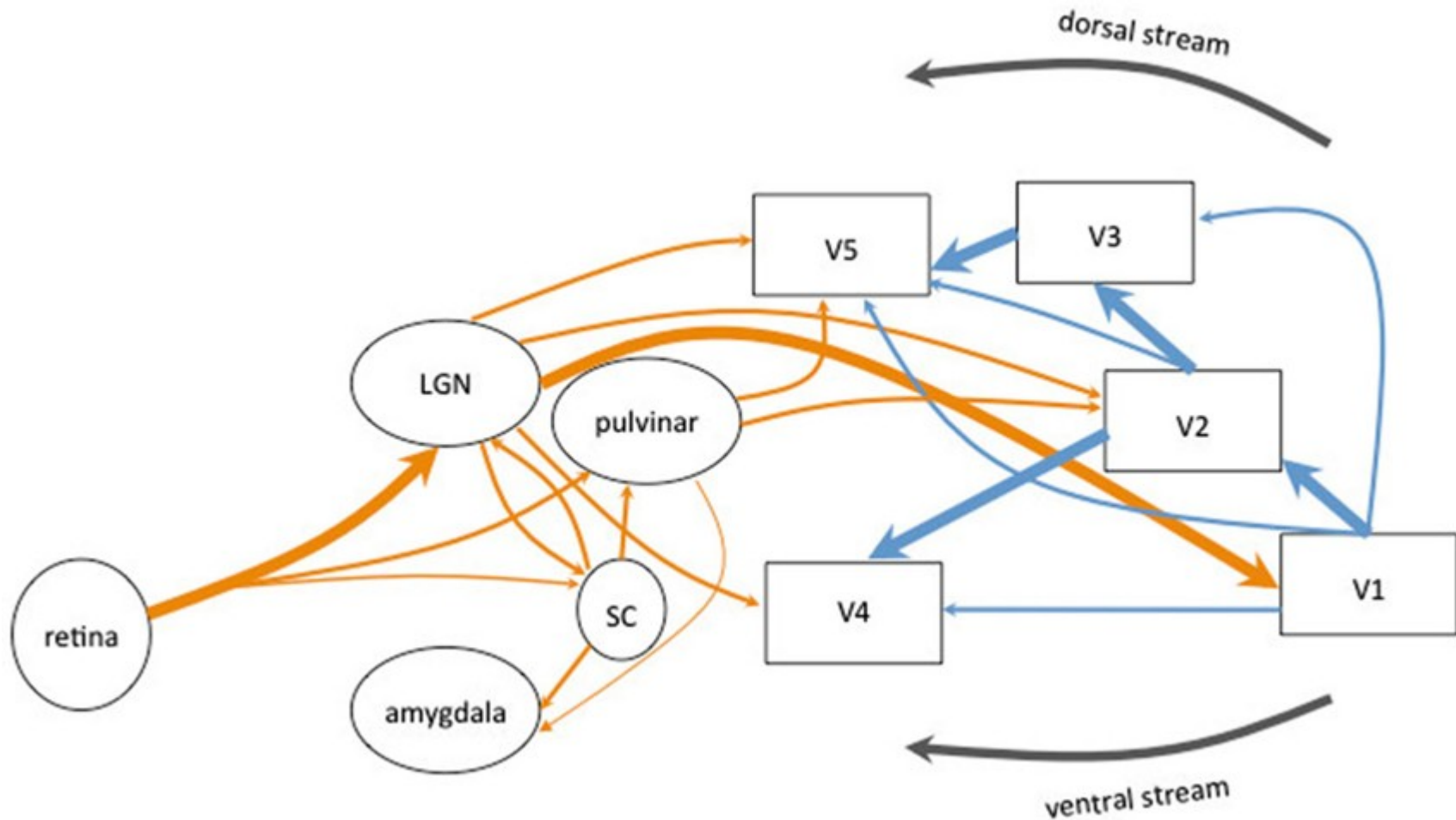

Urbanski, Marika, Olivier A. Coubar, and Clémence Bourlon. "Visualizing the blind brain: brain imaging of visual field defects from early recovery to rehabilitation techniques." *Neurovision: Neural bases of binocular vision and coordination and their implications in visual training programs* (2014).

Convolutional Neural Networks

- Convolutional neural networks use the same trick of learning layers of localized features...
- CNN's were actually being used by Yann Lecun at Bell Labs around 1990

Convolutions

Grayscale Image
1 convolutional filter

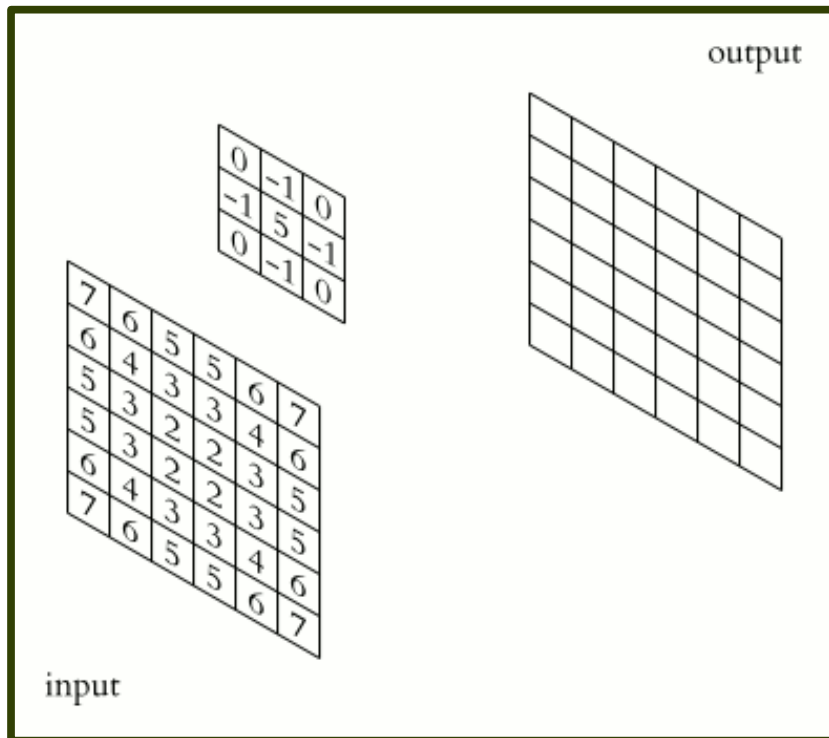

Convolutions

Grayscale Image
1 convolutional filter

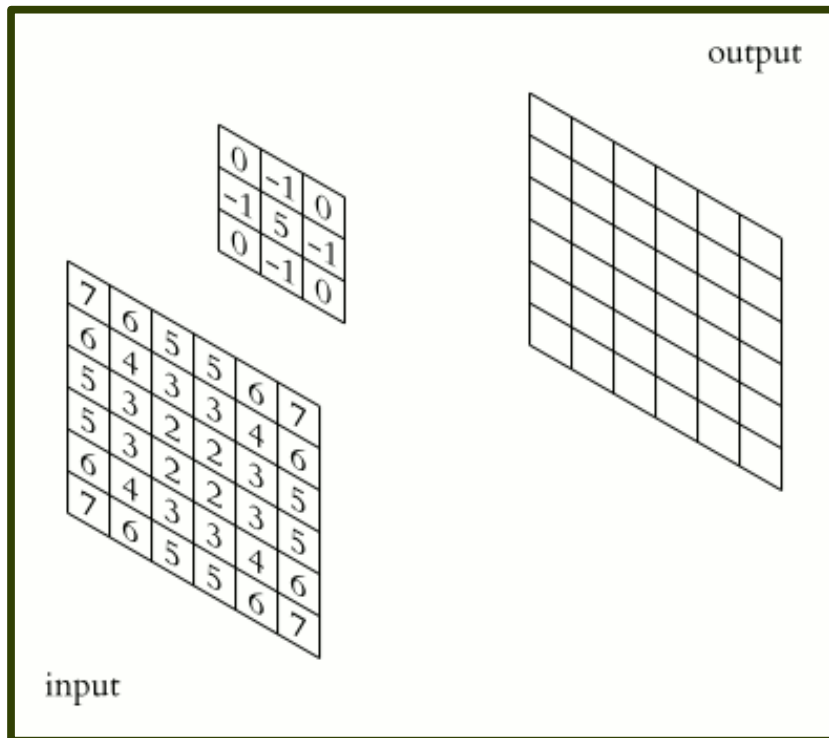

Color Image
5 convolutional filters

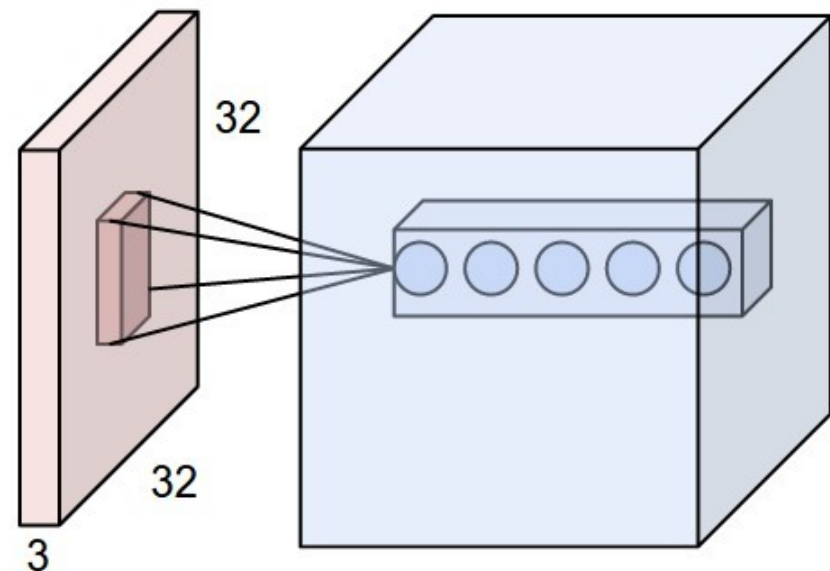

Pooling Layers

- Pooling layers down-sample the filter outputs to
 - Reduce dimensionality and computational requirements
 - Increase the spatial extent of subsequent filters

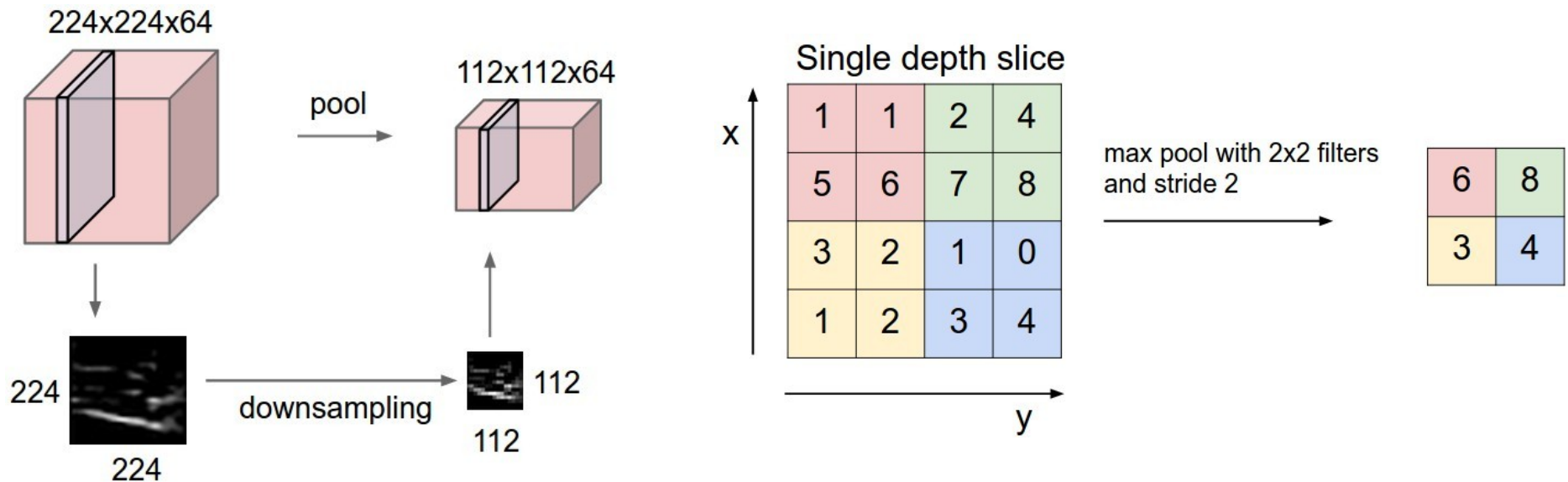

Complete Network

- A “traditional” CNN is composed of convolutional layers, each followed by non-linearities, followed by pooling layers, with a dense (non-convolutional) layer at the end:

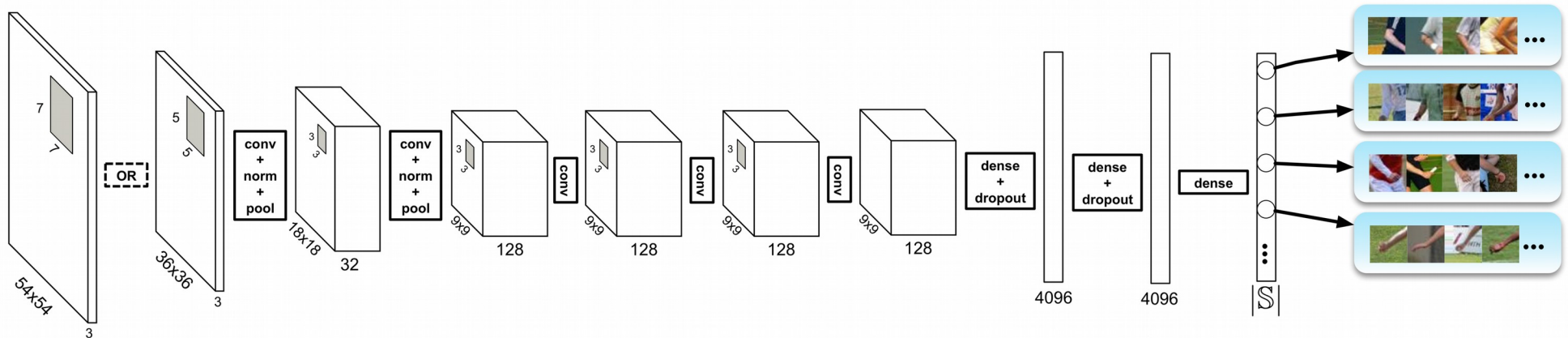

Chen, Xianjie, and Alan L. Yuille. "Articulated pose estimation by a graphical model with image dependent pairwise relations." Advances in Neural Information Processing Systems. 2014.